



Installation instructions for ATS panel Ref:ATS --/4 M2G DS705

This system is designed to monitor the main supply in order to offer protection against phase failure, incorrect phase sequence and under/over voltage.

The installer is responsible for ensuring that the installation conforms to the requirements of BS 7671 (Wiring regulations) and best safe working practice.

We particularly draw your attention to the need for local isolation of both supplies, immediately adjacent to the panel.

SWITCHGEAR SYSTEMS Ltd are able to supply panels with integral isolation to both supplies.

As an alternative, SWITCHGEAR SYSTEMS Ltd also have a comprehensive range of sheet steel enclosed, Load Break Isolators and Switch-Fuses which could be employed.

SETTING UP THE PANEL.

Complete the installation ensuring compliance with BS 7671, and best safe working practice.

1. This panel is fully mains tested prior to leaving SWITCHGEAR SYSTEMS Ltd.
2. When in Auto mode (indicated by LED beside auto button) the DS705 controller will automatically start up and switch over to the linked generator.
3. DS705 requires a constant supply from the battery in the generator start panel. The negative in the start circuit should be wired to 'Gen. Start signal' terminal in the ATS panel. Wire positive side directly to battery.
4. Configuration of DS705 settings are achieved by toggling a small switch located on the top left hand side on the back of the controller. It is partially hidden just behind the PCB to prevent accidental switching.

5. When in config. mode the auto light will flash. Pressing the 'manual on load' button (left) will cycle through the function codes indicated by the 5 left hand LEDs in the row of 8 running across the top. Pressing the 'manual off load' button (middle) will cycle through the settings for these functions indicated by the 3 right hand LEDs.. Pressing the Auto button will save any changes made. Also included is the key to the configuration options.
6. Two additional remote terminals are provided in this ATS panel. If connected to the battery negative via a switch, when switch is closed they will activate with the following effects.
 - Remote close. Closing this terminal to negative will automatically open the contactor, cutting all power to the load. The controller will remain in auto and once this terminals circuit is opened normal operation will resume
 - Remote Generator Start. Closing this terminal to negative will carry out a generator start and switch over. Though the controller will remain in auto mode it will not return to mains supply until this terminals circuit is opened.

ADDITIONAL OPERATIONAL INSTRUCTIONS.

Complete the installation ensuring compliance with BS 7671, and best safe working practice.

1. **Controller Operation.** The four LEDs at the bottom of the panel indicate active supplies. The inner left LED indicates mains active and the inner right LED indicates Generator running. The outer left LED indicates mains contactor closed and the outer right LED indicates Generator contactor closed. The left hand button or 'manual on load' will switch on the generator and switch over the ATS to use this as the active supply. The middle button or 'manual off load' will switch on the Generator but continue to use mains supply. Pressing either of these buttons will turn the panel over to manual mode indicated by the 'Auto' LED turning off. To continue normal function, press the right hand or 'Auto' button.

IN CASE OF DIFFICULTY PLEASE CONTACT SWITCHGEAR SYSTEMS Ltd above.

Functions and configuration table

Function	Function code	Value code	Value (<i>Default in bold Italics</i>)
Start Delay	○ ○ ○ ● ○	○ ○ ○	0 Seconds
		○ ○ ●	5 Seconds
		○ ● ○	10 Seconds
		○ ● ●	15 Seconds
		● ○ ○	20 Seconds
		● ○ ●	30 Seconds
		● ● ○	60 Seconds
		● ● ●	180 Seconds
Mains (utility) return delay	○ ○ ○ ● ●	○ ○ ○	0 Seconds
		○ ○ ●	5 Seconds
		○ ● ○	10 Seconds
		○ ● ●	15 Seconds
		● ○ ○	20 Seconds
		● ○ ●	30 Seconds
		● ● ○	60 Seconds
		● ● ●	180 Seconds
Warming	○ ○ ● ○ ●	○ ○ ○	0 Seconds
		○ ○ ●	5 Seconds
		○ ● ○	10 Seconds
		○ ● ●	15 Seconds
		● ○ ○	20 Seconds
		● ○ ●	30 Seconds
		● ● ○	60 Seconds
		● ● ●	180 Seconds
Cooling	○ ○ ● ● ○	○ ○ ○	0 Seconds
		○ ○ ●	5 Seconds
		○ ● ○	10 Seconds
		○ ● ●	15 Seconds
		● ○ ○	20 Seconds
		● ○ ●	30 Seconds
		● ● ○	60 Seconds
		● ● ●	180 Seconds
Remote start input type	○ ● ● ● ○	○ ○ ○	Remote Start
		○ ○ ●	Simulated mains
Remote start function (Not used when simulated mains is selected)	○ ● ● ● ●	○ ○ ○	Remote start is off load
		○ ○ ●	Remote start is on load
Auxiliary Output 1 Function	● ○ ○ ● ○	○ ○ ○	Not Used
		○ ○ ●	Mains (utility) Fail
		○ ● ○	Generator Available
		○ ● ●	Generator on Load
		● ○ ○	Mains On Load
		● ○ ●	System in Auto
		● ● ○	Close to Neutral position
		○ ○ ○	Not Used
Auxiliary Output 2 Function	● ○ ○ ● ●	○ ○ ○	Not Used
		○ ○ ●	Mains (utility) Fail
		○ ● ○	Generator Available
		○ ● ●	Generator on Load
		● ○ ○	Mains On Load
		● ○ ●	System in Auto
		● ● ○	Close to Neutral position
		○ ○ ○	60V / 70V
Mains (utility) Under Voltage	● ○ ● ○ ○	○ ○ ●	70V / 80V
		○ ● ○	80V / 90V
		○ ● ●	90V / 100V
		● ○ ○	120V / 140V
		● ○ ●	140V / 160V
		● ● ○	160V / 180V
		● ● ●	180V / 200V

Customer Connection Diagram ATS -/4 M2G DS705

I in	Terminal size
40A	25mm Cage
63A	25mm Cage
80A	25mm Cage
100A	35mm Cage
125A	70mm Cage
160A	M10 Lug
200A	M10 Lug
250A+	M12 Lug

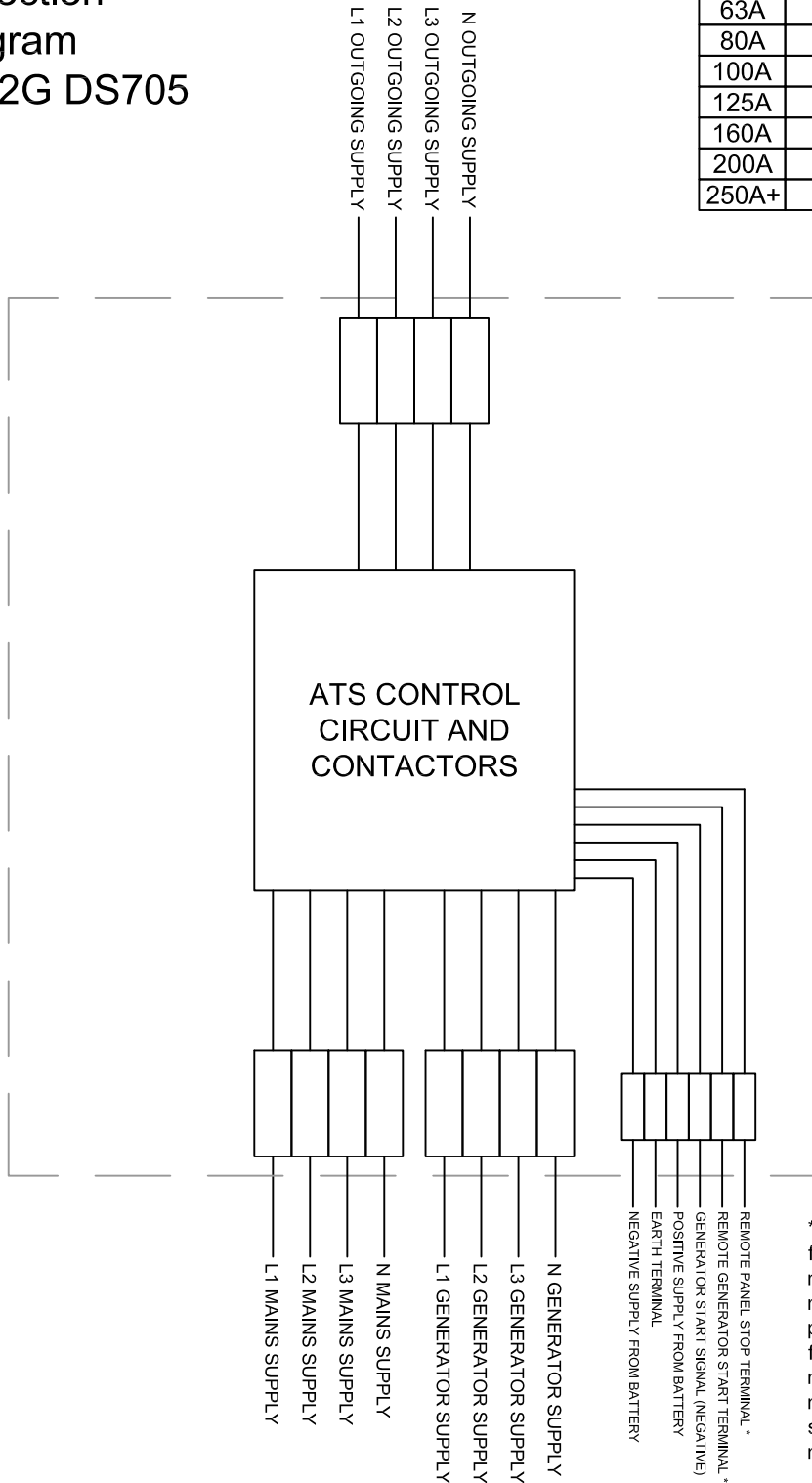

* These Terminals are for remote operation and not required for the normal running of the panel. To Activate these features, these terminals must be wired to battery negative with a n/o switch (i.e. close to negative to activate)

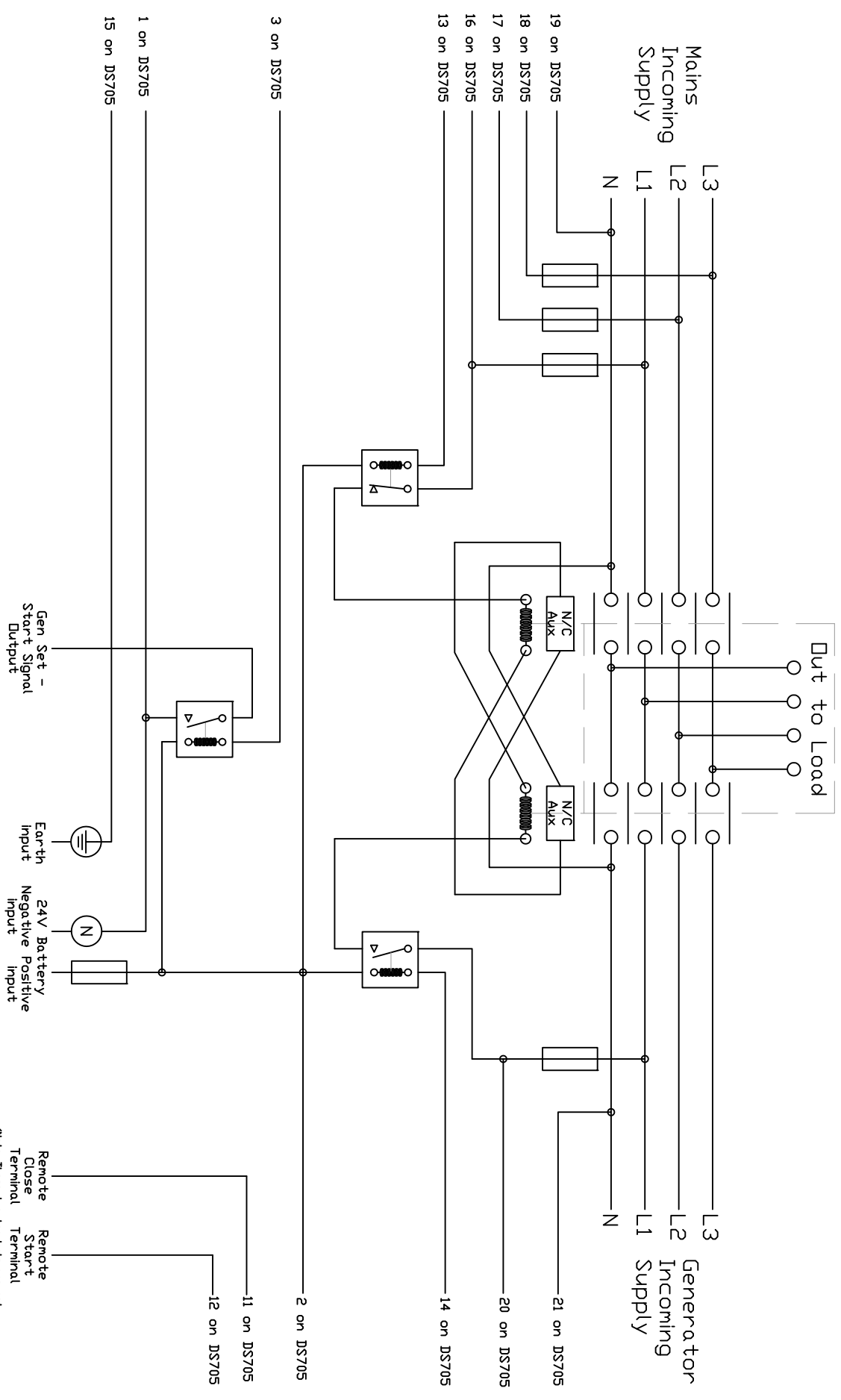

Note: These two terminals are not to be used unless you have written instructions for their application.



16 Woodside Park, Rugby, Warwickshire, CV21 2NP. Tel: 01788 577399. Fax: 01788 577899. E: mail@switchgear-systems.com

Reference: ATS --/4 M2G DS705 Wiring Diagram

Info: Scale: n/a Date Drawn: 07.01.09 Drawn By: R.J.Plumley